

Model	Enclosure Design	Frequency Response	Efficiency	Power / imp.
BT15121H	Bassreflex Hoorn	53~ 153Hz -3dB	99dB 1W/1M	450W AES/8ohm
Components	Kast: Fins multiplex 18mm		Netto inhoud: r 108Lts / f 30Lts	
	Bass: 18Sound 15W700 38Hz-3000Hz/450W/8ohm			
	Highpass 30Hz / Lowpass 140Hz 4de order - EQ 140Hz/Q=2/G=+2dB			
Ontwerp: van den Hoogen's Servicebedrijf / Boi van den Hoogen / www.boyzpc.nl / 06-08-2006				

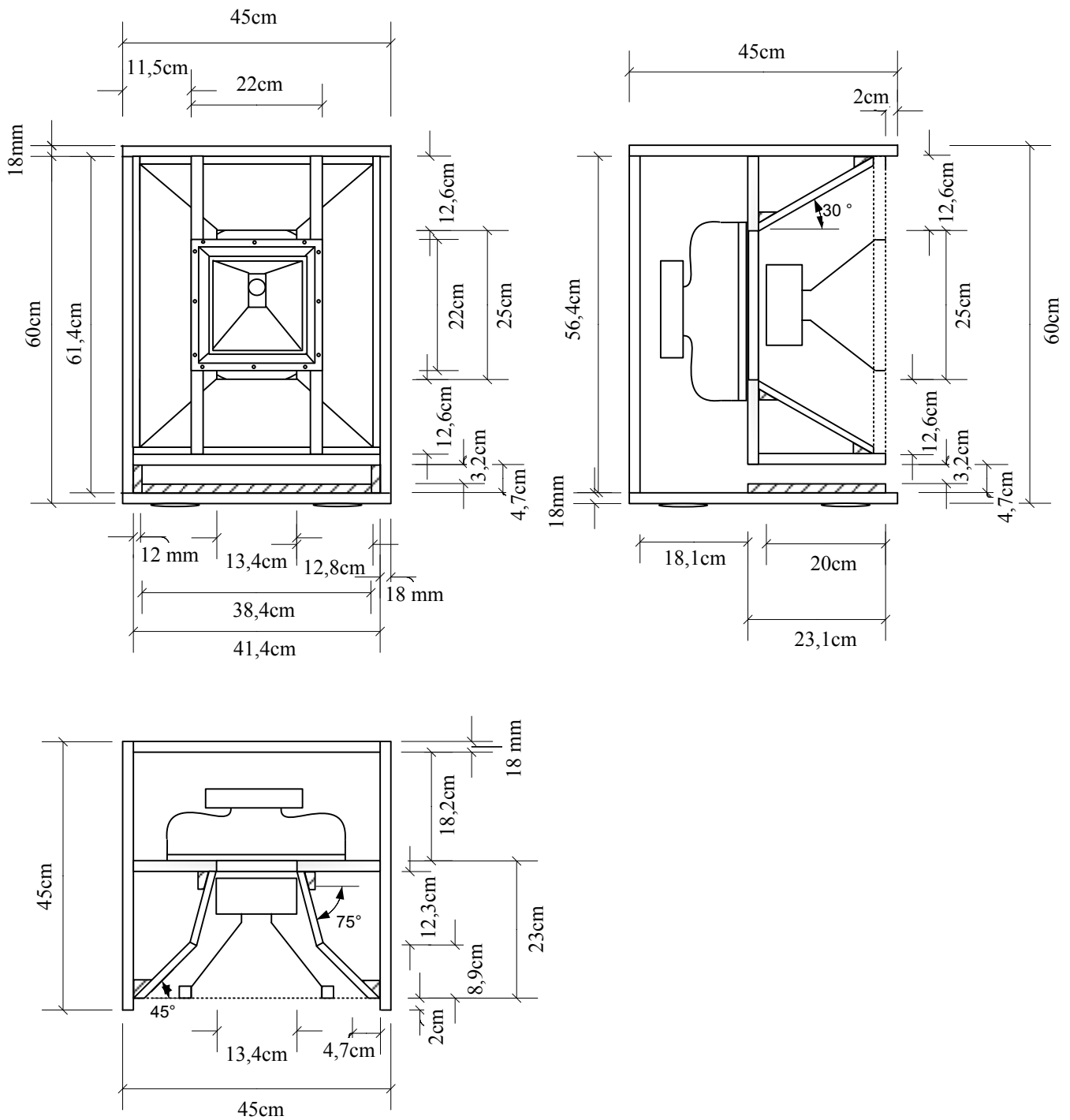

Model	Enclosure Design	Frequency Response	Efficiency	Power / imp.
BT15121H	Coaxiale top	132~ 20KHz -3dB	101dB 1W/1M	400W AES/8ohm
Components	Kast: Fins multiplex 18mm		Netto inhoud r kamer: 42Lts	
	Bass/mid: SL SP12A-300neo 60Hz-3,5KHz/300W/8ohm		passief filter 2000Hz 12dB/okt/8ohm	
	High: SL MRD180 1,6KHz-20KHz/80W/8ohm / Hoorn RCF HF100 90*70			
	Highpass 140Hz/4de order EQ 140Hz/Q=2/G=+4dB			
Ontwerp: van den Hoogen's Servicebedrijf / Boi van den Hoogen / www.boyzpc.nl / 06-08-2006				