

Technical Specifications

Acoustic cabinet:	FR12B
Description:	2 Way System. 12" and High Frequency unit
Power AES:	350 W.
Power Program:	700 W.
Sensitivity 2,83v @ 1m:	97 dB.
Max. SPL continuous:	122 dB.
Max. SPL peak:	128 dB.
Frequency response:	45 - 20.000Hz.
Coverage (H x V):	80° x 50°
Bass Loudspeakers:	12MW/ND
Compression Driver:	CP755/ND
Constant Directivity Horn:	TD-385
Crossover:	FP-12B/1
Hardware:	External

Front**Lateral****Base**

Rear

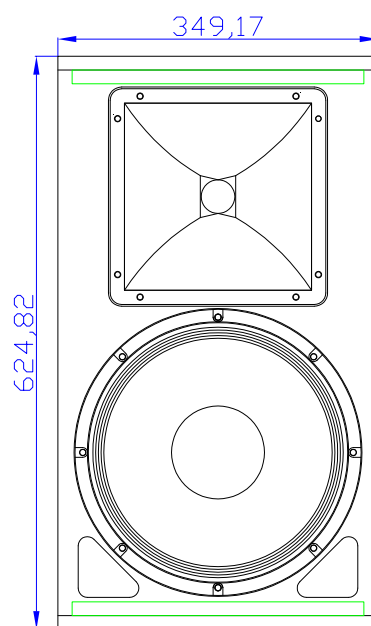
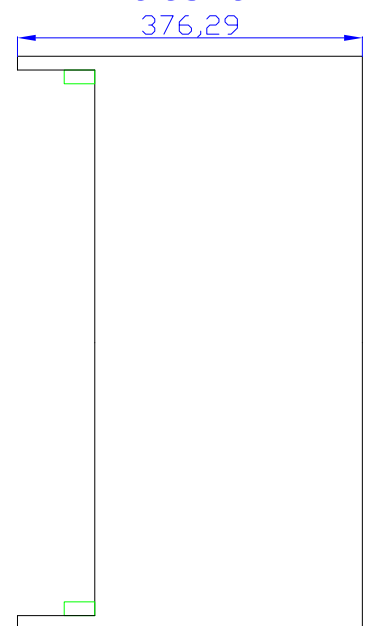
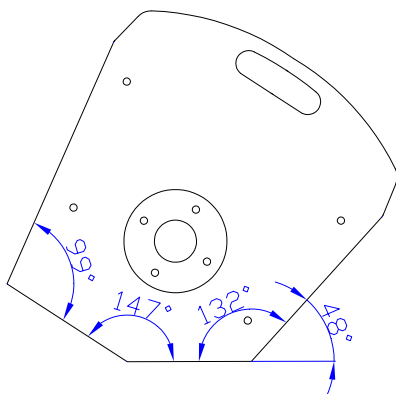
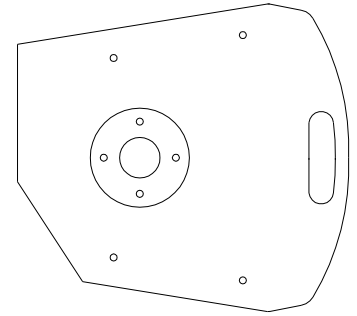
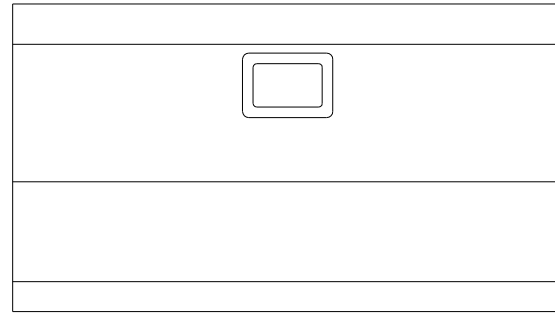
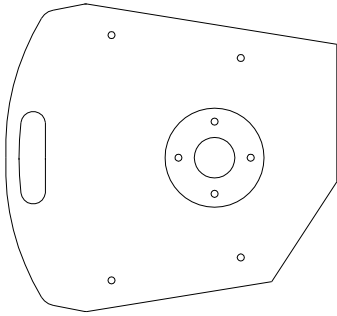

Base

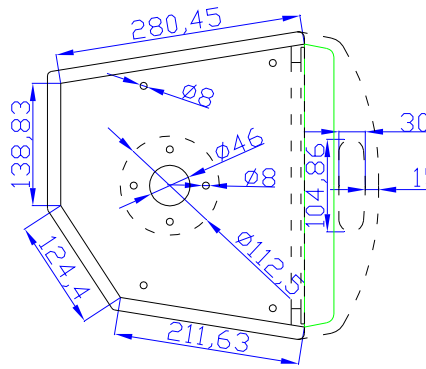

Front

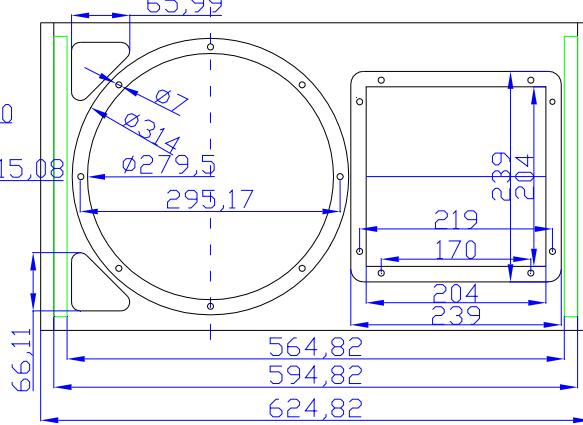

Central

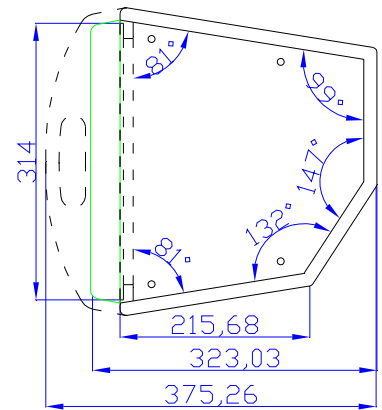

Front

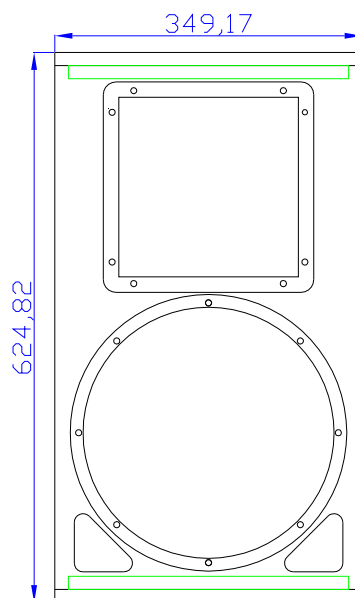

Lateral

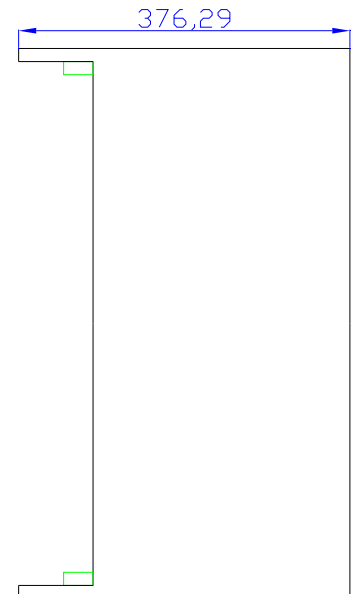

Base

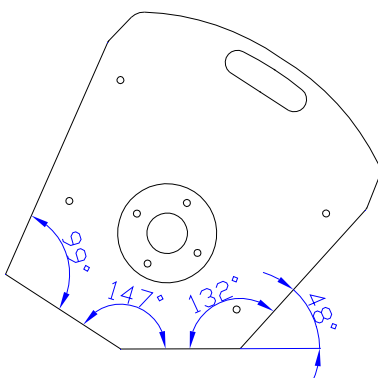

12MWNd

KEY FEATURES

- Good power handling (350 W AES)
- Sensitivity: 97 dB @ 2.83V
- Extended frequency response (35-5000 Hz)
- Neodymium magnets
- Aluminium customized basket



TECHNICAL SPECIFICATIONS

- Nominal diameter 300 mm. 12 in.
- Rated impedance 8 ohms
- Minimum impedance 7 ohms
- Power capacity* 350 w AES
- Program power 700 w
- Sensitivity 97 dB 2.83v @ 1m @ 2π
- Frequency range 35 - 5000 Hz
- Voice coil diameter 62.4 mm. 2.5 in.
- Magnetic assembly weight 2.54 kg. 5.59 lb.
- BL factor 16.9 N / A
- Voice coil length 19.5 mm
- Air gap height 10 mm
- X damage (peak to peak) 30 mm

Notes:

*The power capacity is determined according to AES2-1984 (r2003) standard.
Program power is defined as the transducer's ability to handle normal music program material.

DIMENSION DRAWINGS

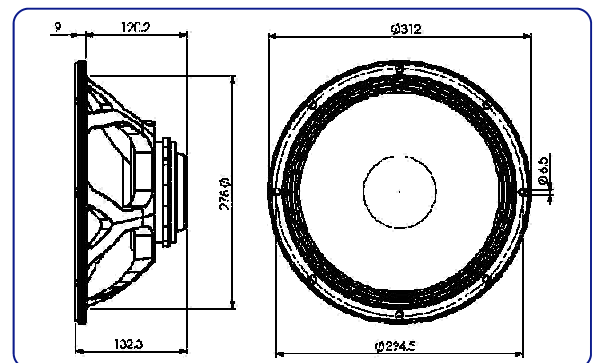

CP-755Nd

KEY FEATURES

- Composite structure diaphragm (Titanium dome & Mylar surround)
- Light neodymium magnet
- Optimized titanium phasing plug
- Superior high frequencies sound reproduction quality
- Extended frequency response (0.6 - 20 kHz)
- High sensitivity (112 dB)



TECHNICAL SPECIFICATIONS

- Throat diameter 3.6 mm. 1.4"
- Rated impedance 8 ohms
- D.C. Resistance 5.5 ohms
- Power capacity* 70 w AES above 1 kHz
- Program power 140 w above 1 kHz
- Sensitivity** 112 dB 1w @ 1m
- Frequency range 600- 20000 Hz
- Voice coil diameter 72.2 mm. 2.87 in.
- Recommended Crossover 800 Hz or higher (12 dB/oct. min.)
- Net weight 2.96 kg. 6.51 lb.

Notes:

*The power capacity is determined according to AES2-1984 (r2003) standard.
Program power is defined as the transducer's ability to handle normal music program material.
**Sensitivity was measured at 1 m distance, on axis, with 1 w input, averaged in the range 1 - 7 kHz and Coupled to a TD565 horn.

DIMENSION DRAWINGS

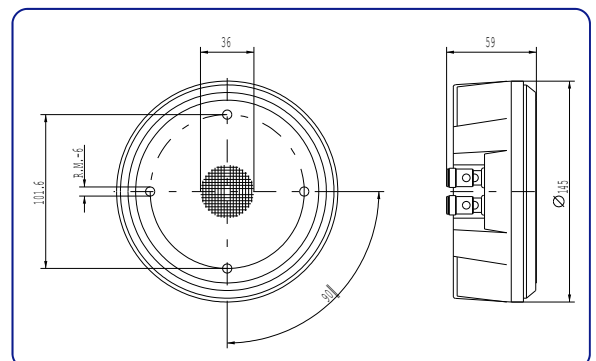

TD-385

KEY FEATURES

- Designed for compression drivers with 1.4" throat diameter
- It provides uniform response, on and off-axis with a neutral and natural frequency reproduction
- Coverage angles of 80° in the horizontal plane and 50° in the vertical plane
- Precise directivity control in the pass band
- Its square form provides more versatility when mounting in the enclosure

TECHNICAL SPECIFICATIONS

- Throat diameter 36 mm. 1.4 in.
- Horizontal beamwidth 80° (+16°, -32°)
(-6 dB, 1 - 20 kHz)
- Vertical beamwidth 50° (+29°, -14°)
(-6 dB, 1.6 - 20 kHz)
- Directivity factor (Q) 12.4 (average 0.63 - 16 kHz)
- Directivity index (DI) 10.5 dB (+3.5 dB, -3.2 dB)
- Cutoff frequency 800 Hz
- Dimensions (WxHxD) 235x235x120 mm.
9.25x9.25x4.72 in.
- Cutout dimensions (WxH) 204x202 mm.
8.03x7.95 in.
- Net weight 1.2 kg. 2.64 lb.
- Shipping weight 1.53 kg. 3.37 lb.
- Construction Cast aluminium.
Connection of driver by four screws on a 101.6 mm. diameter bolt circle.



DIMENSION DRAWINGS

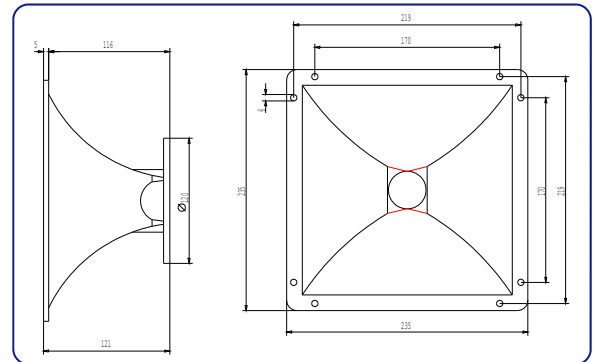

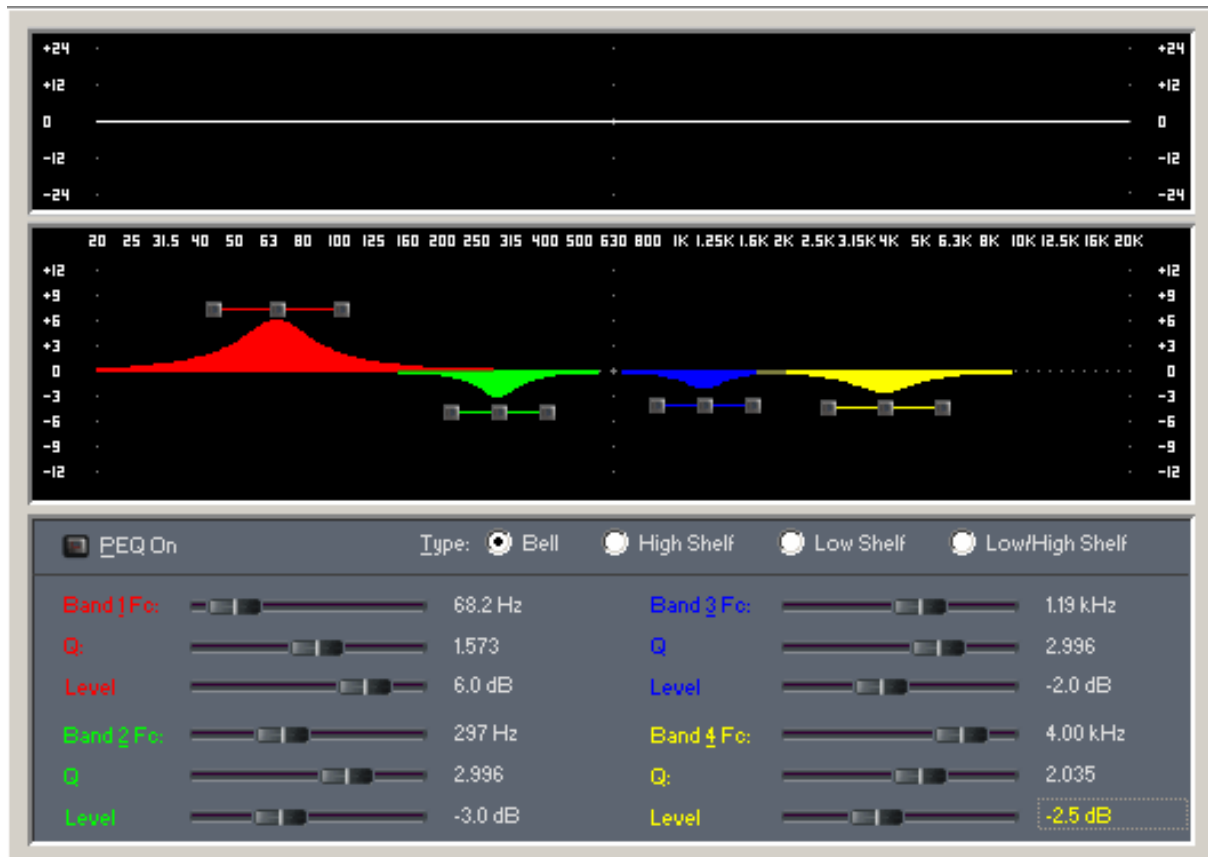

FR12B/1 Crossover

